

091/F9M1FSY

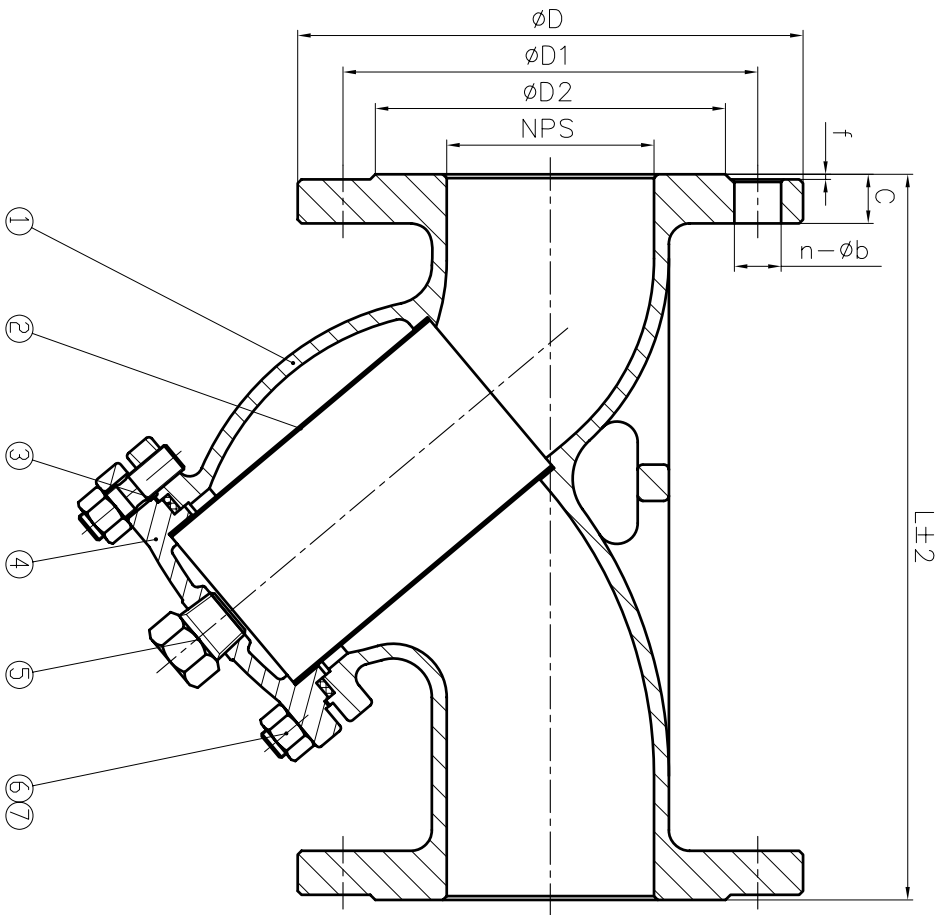

NPS	L	D	D1	D2	C	f	n-φb	Weight (lb)
1/2"	5.118	3.543	2.374	1.374	0.394	0.063	4-φ0.630	5.512
3/4"	5.512	3.937	2.752	1.698	0.433	0.063	4-φ0.630	6.614
1"	5.906	4.331	3.126	2.000	0.472	0.063	4-φ0.630	7.716
1 1/4"	6.693	4.528	3.500	2.500	0.512	0.063	4-φ0.630	11.023
1 1/2"	7.874	4.921	3.874	2.874	0.591	0.063	4-φ0.630	14.330
2"	8.661	5.906	4.752	3.626	0.630	0.063	4-φ0.748	16.535
2 1/2"	9.921	7.087	5.500	4.126	0.709	0.063	4-φ0.748	25.353
3"	11.024	7.480	6.000	5.000	0.748	0.063	4-φ0.748	29.762
4"	12.598	9.055	7.500	6.189	0.945	0.063	8-φ0.748	47.399
5"	13.780	10.039	8.500	7.311	0.945	0.063	8-φ0.866	46.218
6"	15.748	11.024	9.500	8.500	1.024	0.063	8-φ0.866	68.343
8"	19.094	13.583	11.752	10.626	1.142	0.063	8-φ0.866	141.096

NOTE:

1. Design and Manufacture for valve according to ANSI B16.34-2009.
2. End Flange dimensions for valve according to ASME B16.5-2009.
3. Inspection and Test for valve according to API 598-2009.

Nominal pressure		150LB					
Test pressure	Shell test	3.0	MPa	test medium	water	Test temperature	normal temperature
	Gas seal test	0.6			air		
Applicable medium		water, oil, gas					
Applicable temperature		-20~797°F					

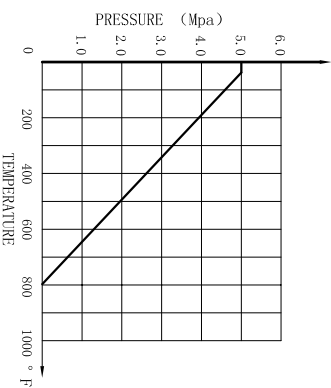

7	NUT	-	A194 8
6	STUD	-	A193 B8
5	PLUG	1	A351 CF8M
4	BONNET	1	A351 CF8M
3	GASKET	1	SS316+Graphite
2	BASKET	1	SS316
1	BODY	1	A351 CF8M
NO.	DESCRIPTION	QTY	MATERIAL
MARK		BEFORE MODIFIED	AFTER MODIFIED
DRA.		APP.	DATE
CHK.		DATE	
		SCALE	
		ANIX VALVE CO., LTD	
		Flanged Y-Strainer	
		150LB, CF8M	
		YS41W6F/150	